

**Maximum Length 8,8m  
total weight empty 8,8m 1,4 tonn**

Drain 1 1/2" 3 x 1 1/2"

2 x 1 1/2"

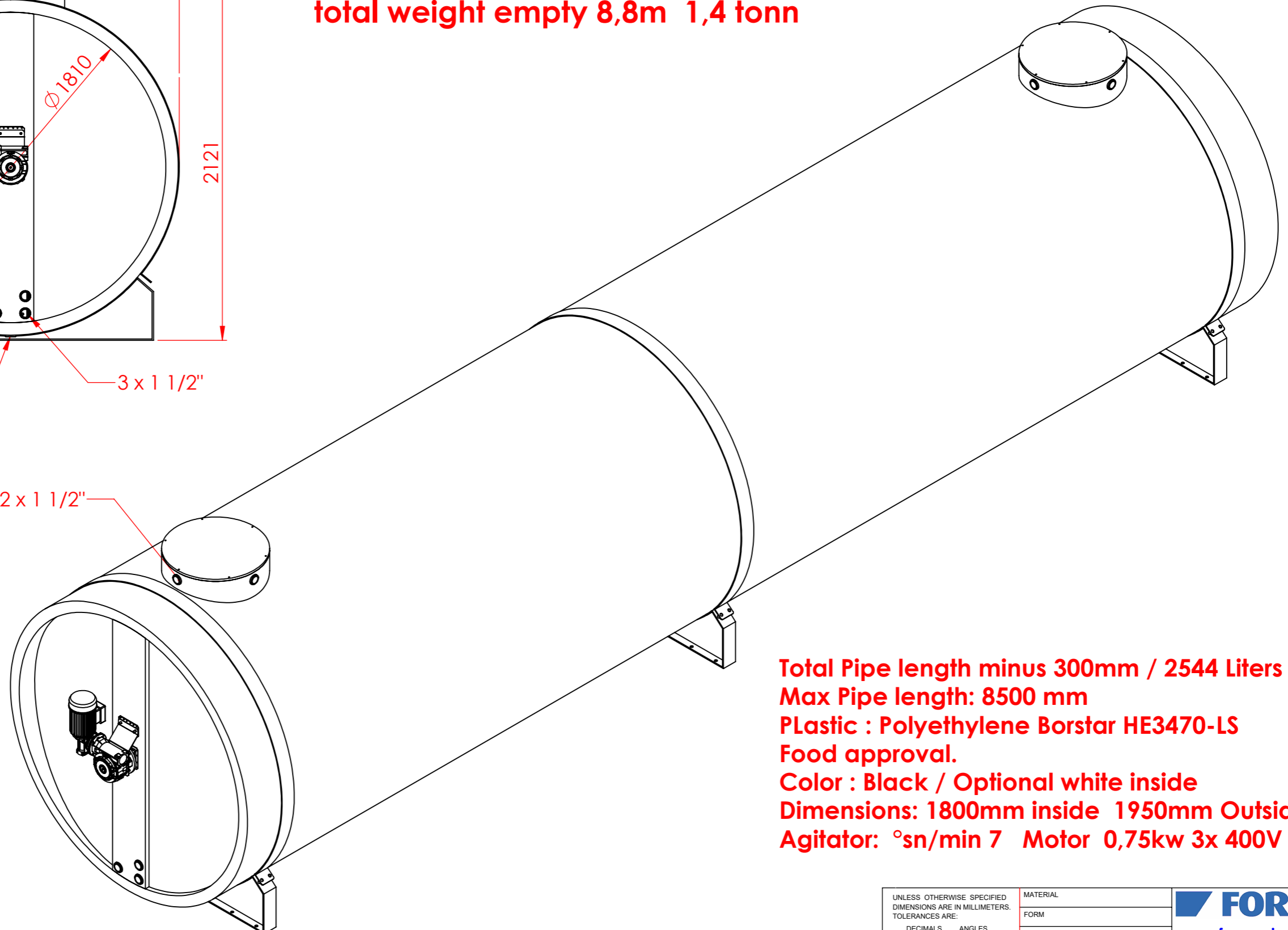

**Total Pipe length minus 300mm / 2544 Liters per meter.  
Max Pipe length: 8500 mm  
PLastic : Polyethylene Borstar HE3470-LS  
Food approval.  
Color : Black / Optional white inside  
Dimensions: 1800mm inside 1950mm Outside  
Agitator: °sn/min 7 Motor 0,75kw 3x 400V 50/60hz**

UNLESS OTHERWISE SPECIFIED DIMENSIONS ARE IN MILLIMETERS. TOLERANCES ARE:		MATERIAL		<b>FORMAX</b> www.formax.is Tel: +354 562 6800 Fax: +354 562 6808 mobile +354 660 6868	
DECIMALS .X ± .3 .XX ± .1 .XXX ± .05		ANGLES X ± 1° X ± .5° .XX ± .25°			
DO NOT SCALE DRAWING FIRST ANGLE PROJECTION		PRODUCTION GROUP		SPAREPART	
PROCESS		FINISH		ST 1800 Liquid Ice-tank Double Wall Insulation 75mm	
DESIGNED BY Bjarni	DATE 19.09.2013	DRAWN BY Bjarni	DATE -	REPLACES	REPLACED BY
APPROVED BY -	DATE -	CHECKED BY -	DATE -	SIZE A3	DWG NO.
FORMAX CONFIDENTIALITY AGREEMENT NOTICE: INSO FAR AS THIS DRAWING EMBODIES A CONFIDENTIAL PROPRIETARY DESIGN OWNED BY FORMAX. NOTICE IS HEREBY GIVEN THAT ALL DESIGN, MANUFACTURING, REPRODUCTION USE AND SALES RIGHTS REGARDING THE SAME ARE EXPRESSLY RESERVED TO FORMAX. THIS DRAWING IS SUBMITTED UNDER A CONFIDENTIAL RELATIONSHIP FOR A SPECIFIC PURPOSE AND THE RECIPIENT HERETO AGREES NOT TO DISCLOSE THIS DRAWING OR ANY PORTION OF ITS CONTENTS TO ANY UNAUTHORIZED PERSON, OR TO INCORPORATE THIS PROPRIETARY DESIGN OR THE SUBSTANCE OF IT EITHER IN WHOLE OR IN PART IN ANY OTHER PROJECTS.		SCALE 1:100		CAD FILE: ST-1800-Sale-01	SHEET 1 OF 3